B&B Atoll

SOFAS

Antonio Citterio



Description

Named after the coral formation B&B Atoll, the new modular seating system by Antonio Citterio, is a refined expression of a balanced aesthetic form and a decisive contemporary style that is also extremely elegant. The system is built on three basic platforms - 190 cm and 240 cm, both with 90 cm depth, and 130 cm with 140 cm deep - that are complemented by armrest and backrest elements to form various types of seats: sofas, dormeuses, corner-end modules, single or modular elements with chaise longue and ottomans. The frames have light, slender lines and are applied on high die-cast supports with metal profile emphasising the line between the structure and upholstery. Two finishes are available, pewter and black chrome. The pieces are given even more character by a supporting element to be placed wherever desired, a bolster in two sizes - 65 cm and 90 cm - attached by leather straps to a die-cast structure. This accessory can be inserted between the seat cushion and the base structure to provide an additional support or become an armrest or backrest at will. B&B Atoll is a dynamic project with a constantly

fresh ability to adapt to different compositions and create different seating types, from informal relax versions to most formal, also made possible by the use of complementary back cushions.

Technical information

Internal frame

tubular steel and steel profiles

Internal frame upholstery

Bayfit® flexible cold shaped polyurethane foam, polyester fibre cover

Seat cushion

shaped polyurethane of different density, sterilized down, polyester fibre cover

Back cushion

shaped polyurethane, sterilized down

Lumbar cushion (AT45_40)

down feather, box style typology

Roller

shaped polyurethane, polyester fibre cover

Roller support

die-cast aluminium and leather

Support frame

die-cast aluminium

Ferrules

plastic material

Cover

fabric or leather

Technical drawings

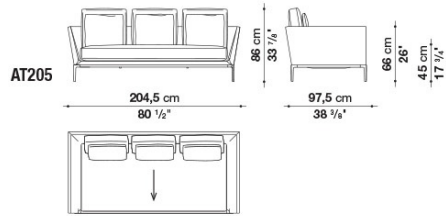

AT205

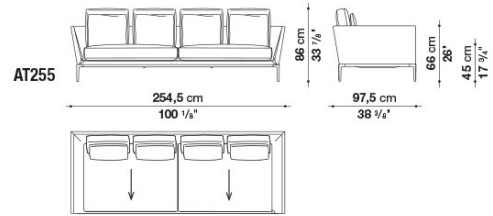

AT255

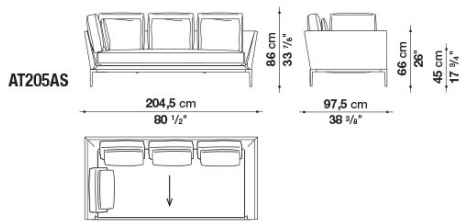

AT205AS

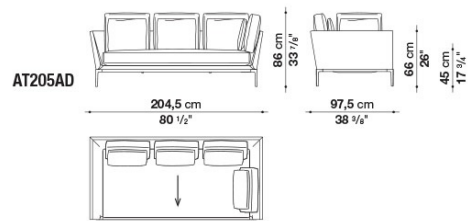

AT205AD

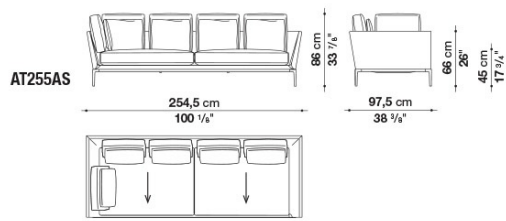

AT255AS

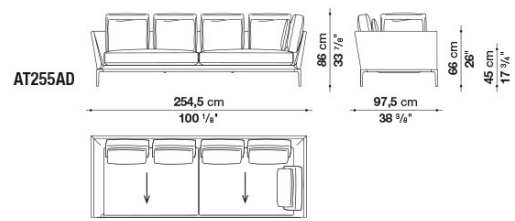

AT255AD

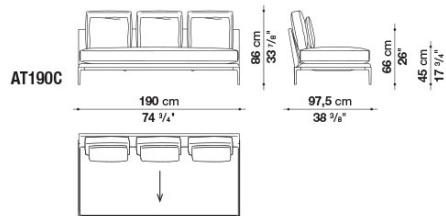

AT190C

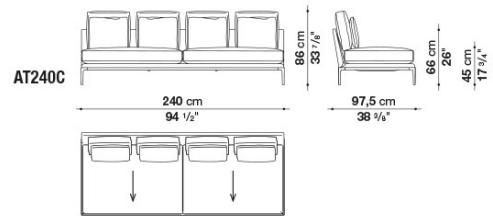

AT240C

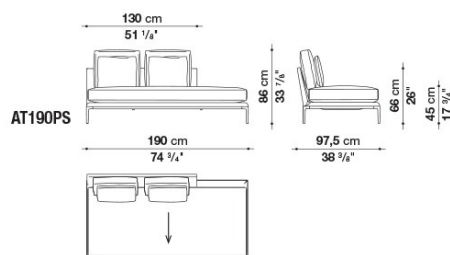

AT190PS

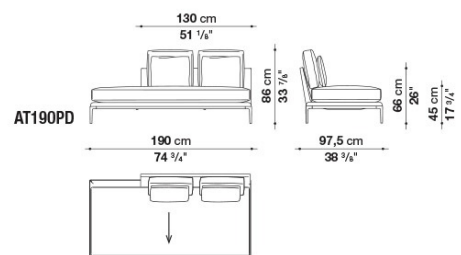

AT190PD

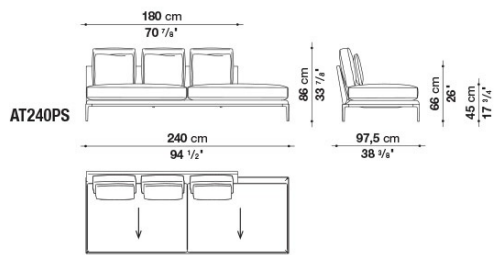

AT240PS

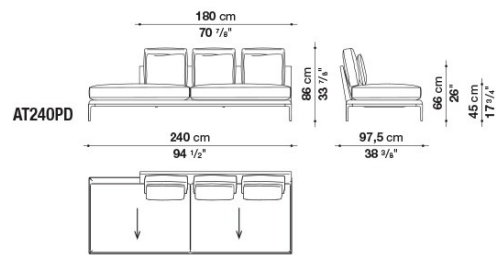

AT240PD

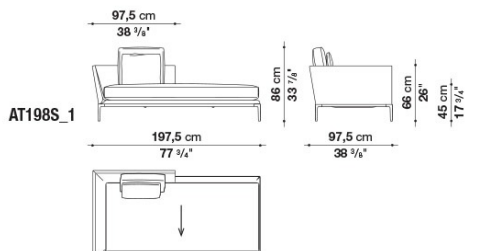

AT198S_1

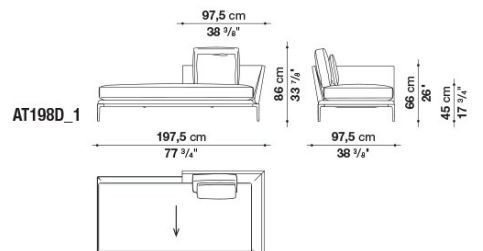

AT198D_1

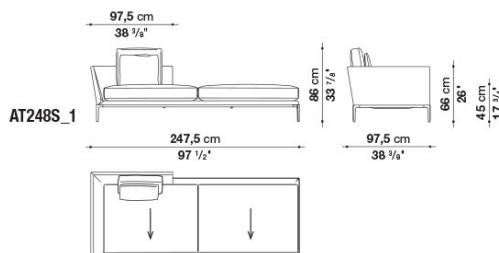

AT248S_1

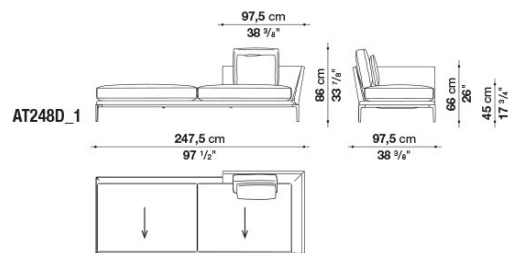

AT248D_1

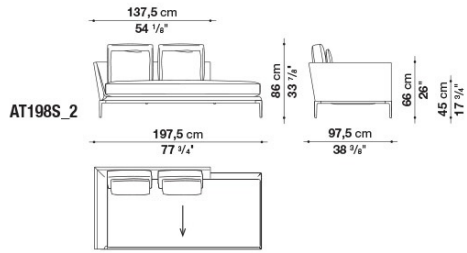

AT198S_2

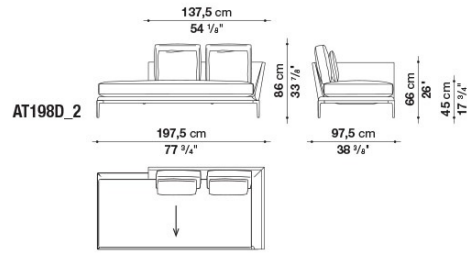

AT198D_2

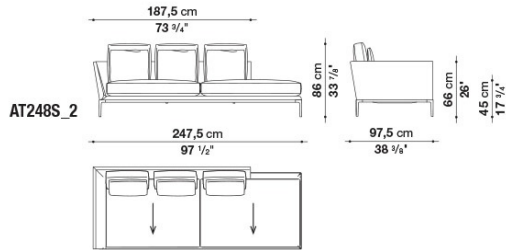

AT248S_2

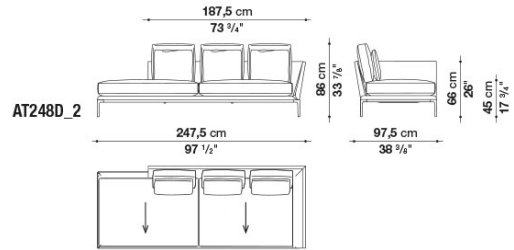

AT248D_2

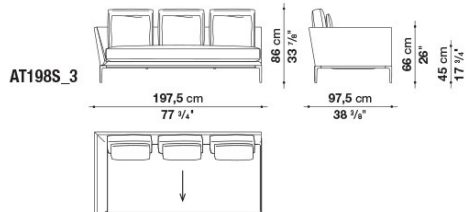

AT198S_3

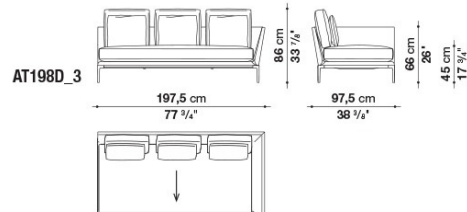

AT198D_3

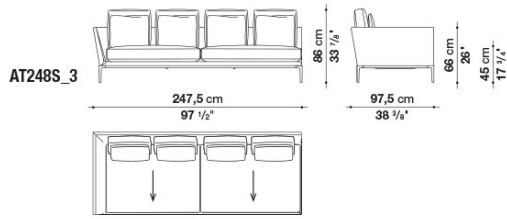

AT248S_3

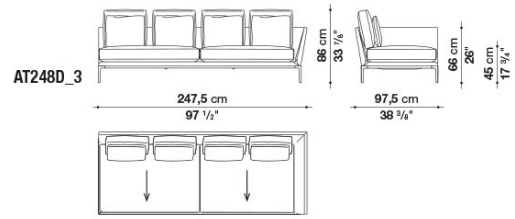

AT248D_3

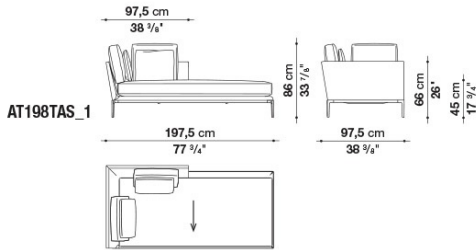

AT198TAS_1

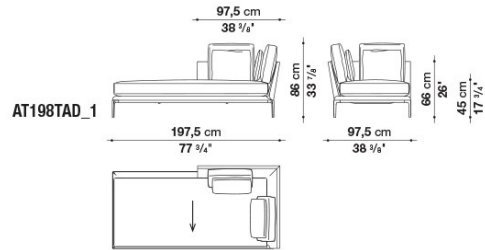

AT198TAD_1

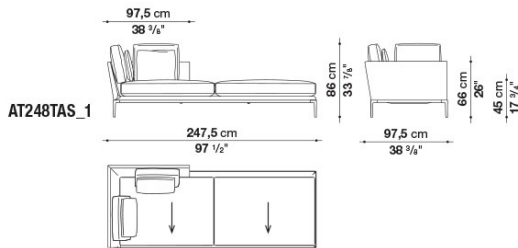

AT248TAS_1

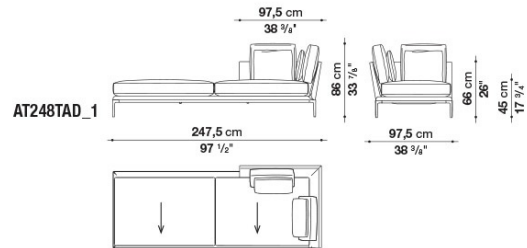

AT248TAD_1

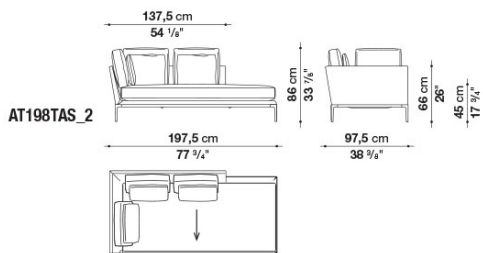

AT198TAS_2

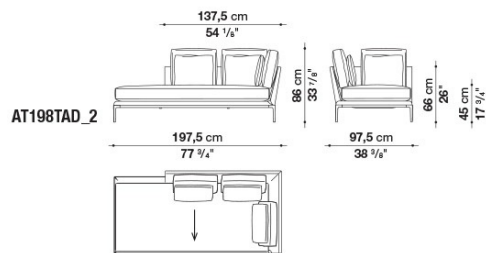

AT198TAD_2

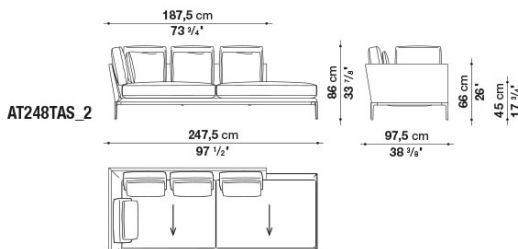

AT248TAS_2

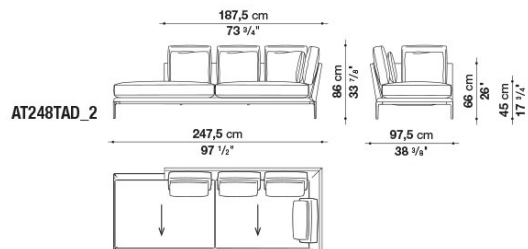

AT248TAD_2

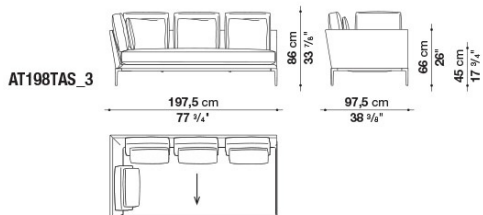

AT198TAS_3

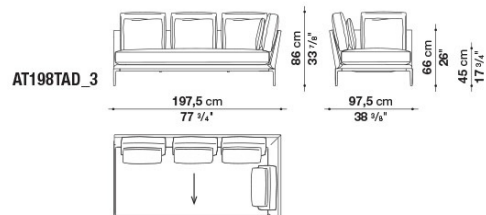

AT198TAD_3

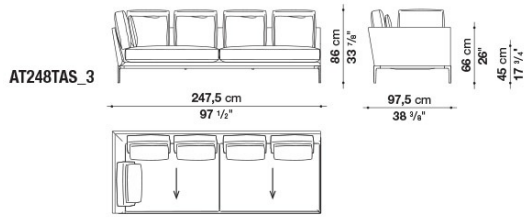

AT248TAS_3

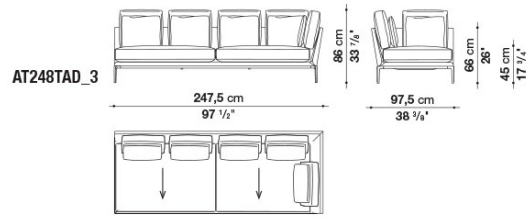

AT248TAD_3

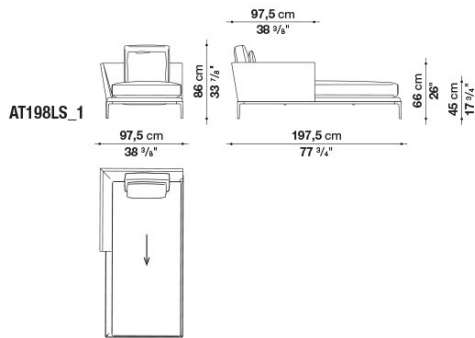

AT198LS_1

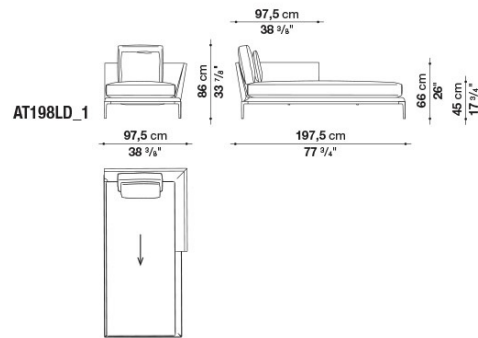

AT198LD_1

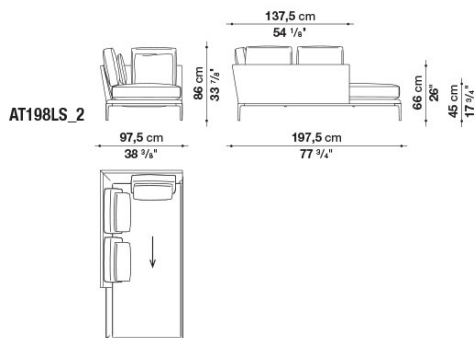

AT198LS_2

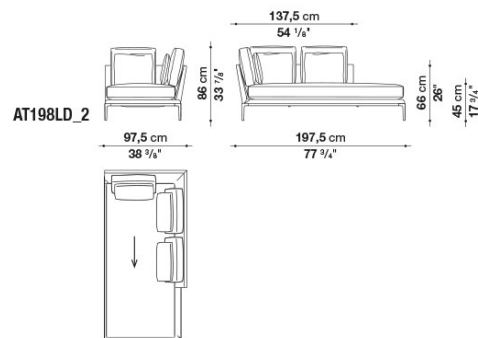

AT198LD_2

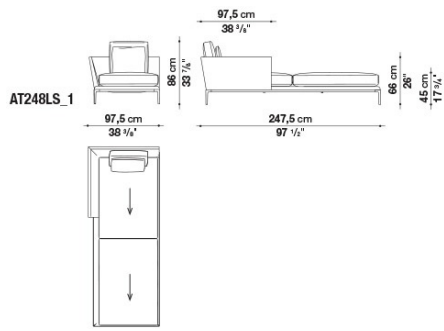

AT248LS_1

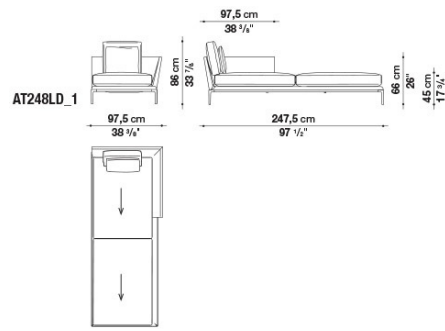

AT248LD_1

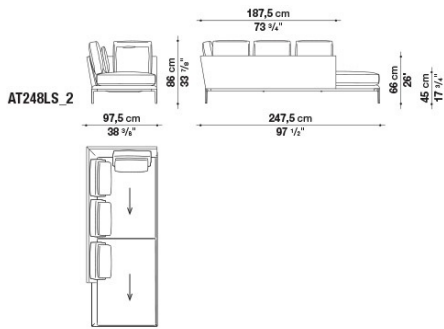

AT248LS_2

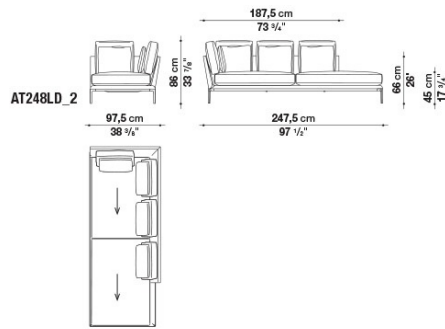

AT248LD_2

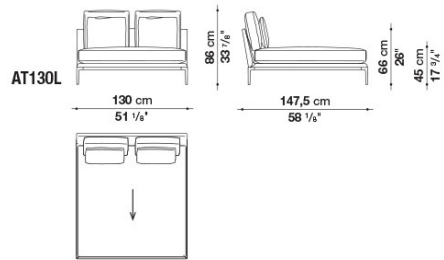

AT130L

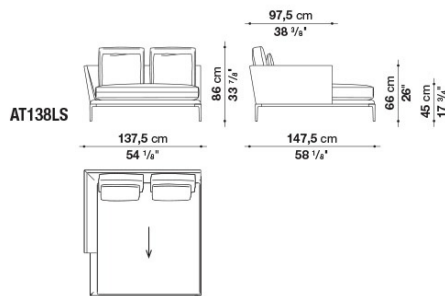

AT138LS

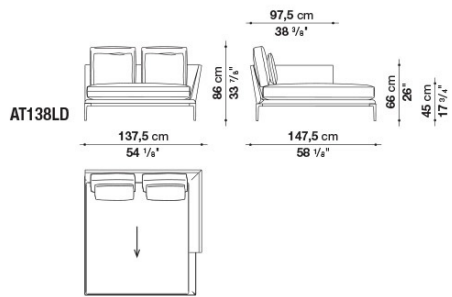

AT138LD

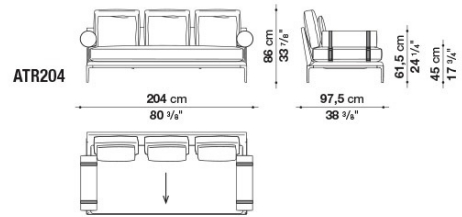

ATR204

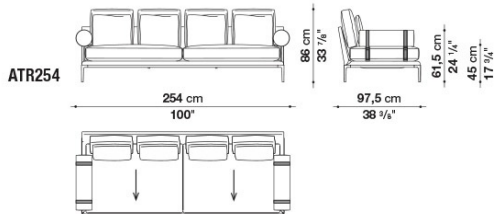

ATR254

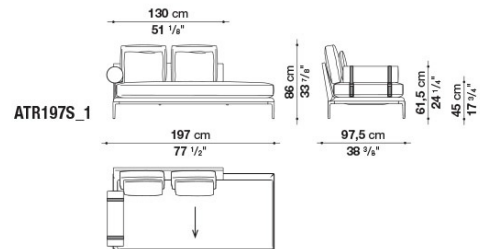

ATR197S_1

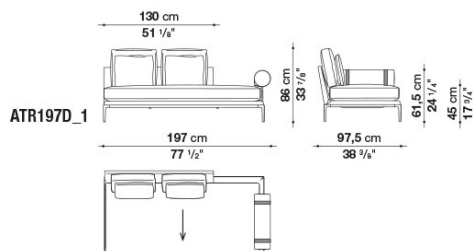

ATR197D_1

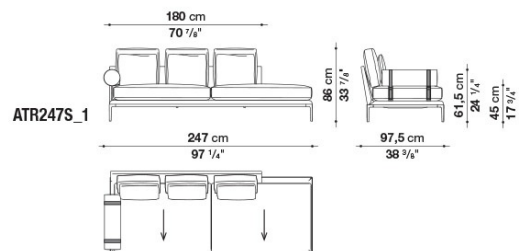

ATR247S_1

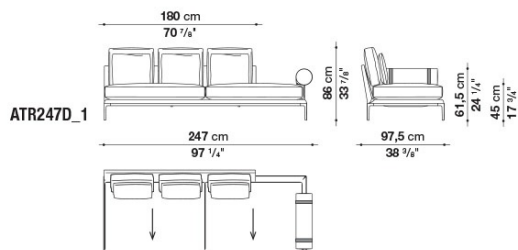

ATR247D_1

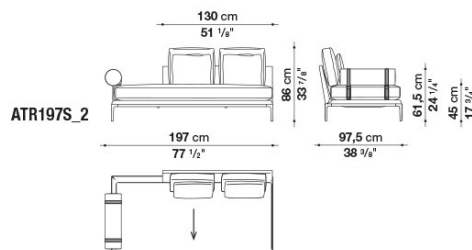

ATR197S_2

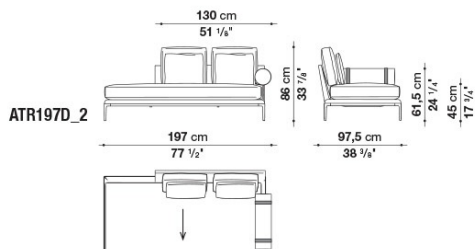

ATR197D_2

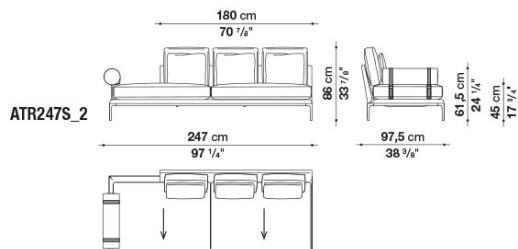

ATR247S_2

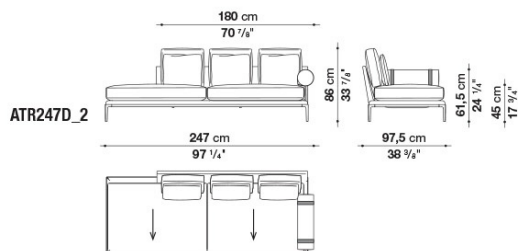

ATR247D_2

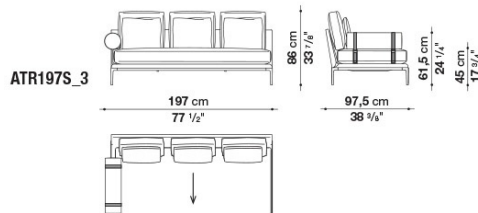

ATR197S_3

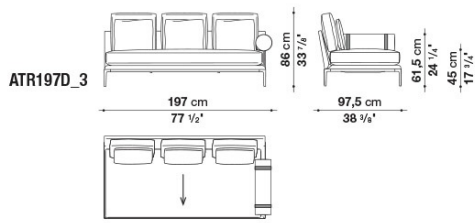

ATR197D_3

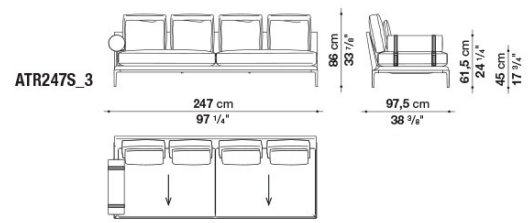

ATR247S_3

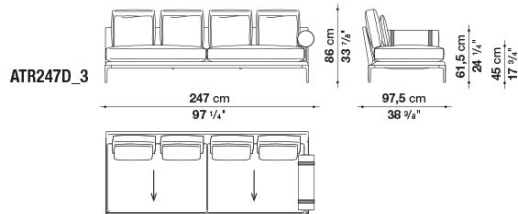

ATR247D_3

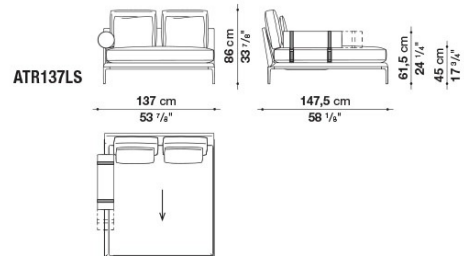

ATR137LS

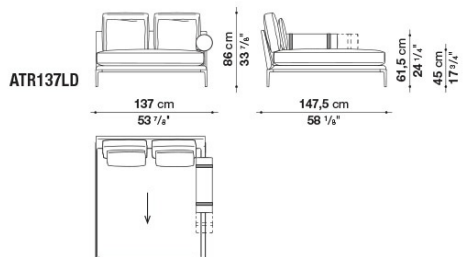

ATR137LD

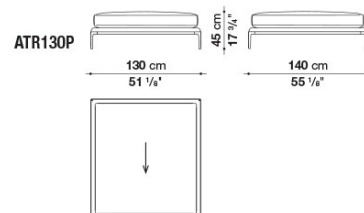

ATR130P

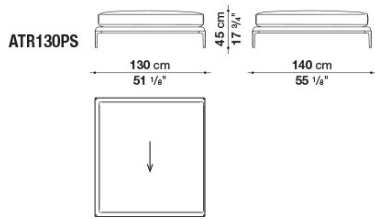

ATR130PS

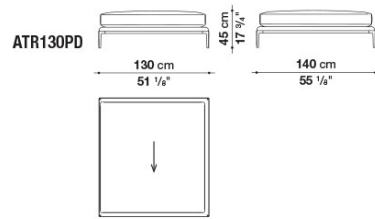

ATR130PD

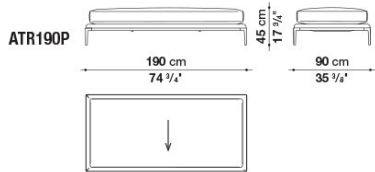

ATR190P

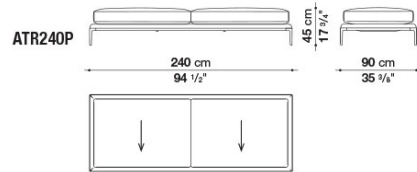

ATR240P

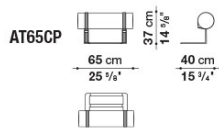

AT65CP

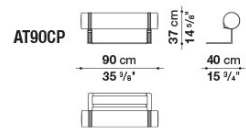

AT90CP

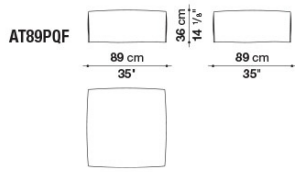

AT89PQF

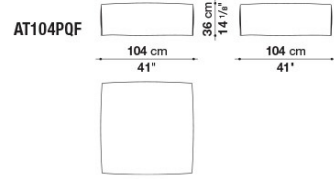

AT104PQF

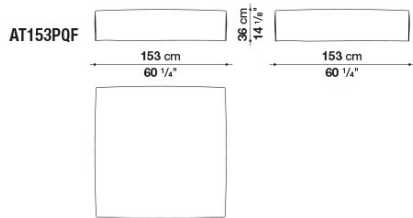

AT153PQF

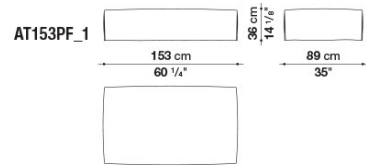

AT153PF_1

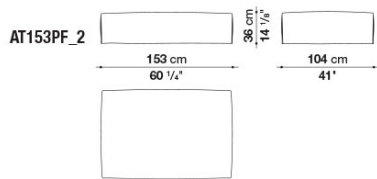

AT153PF_2

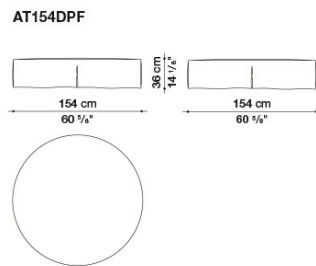

AT154DPF

AT110DPF

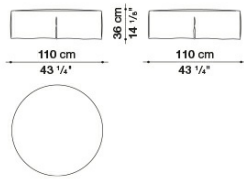

AT110DPF

Compositions

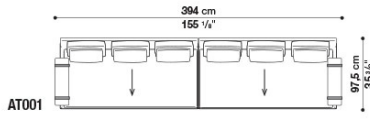

01

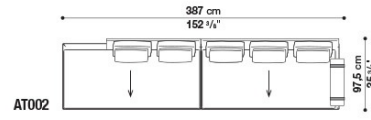

02

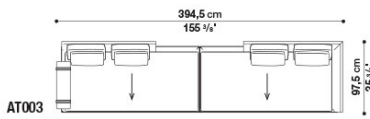

03

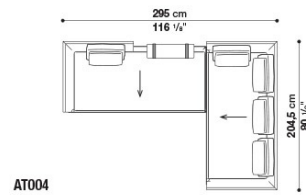

04

AT005

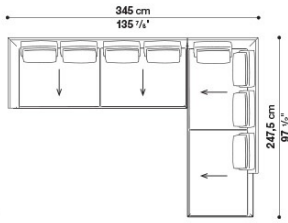

05

AT006

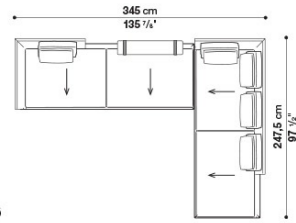

06

AT007

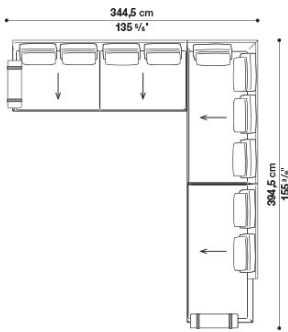

07

AT008

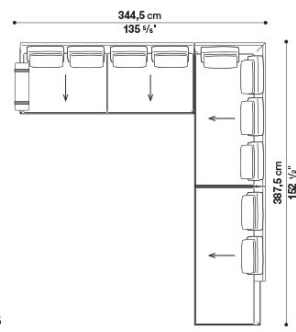

08

AT009

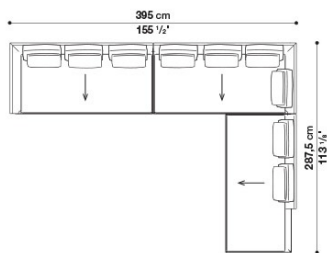

09

AT010

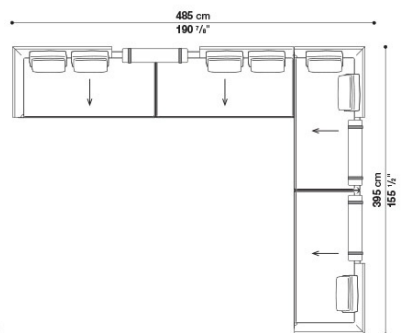

10

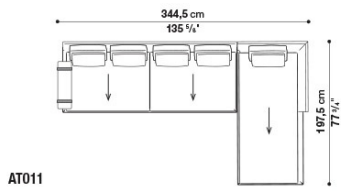

AT011

11

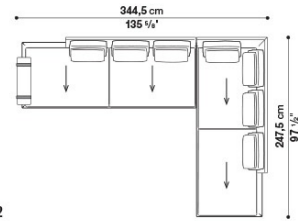

AT012

12

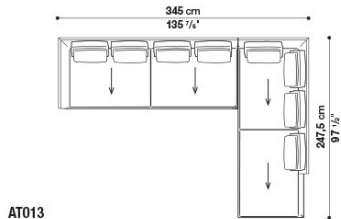

AT013

13

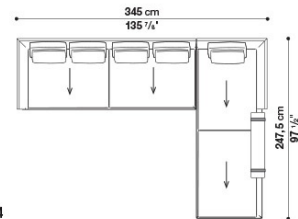

AT014

14

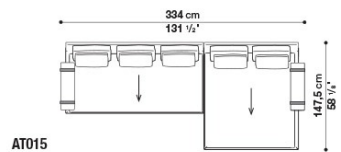

AT015

15

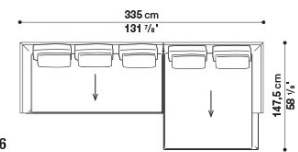

AT016

16

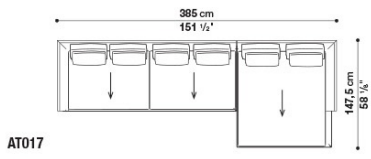

17

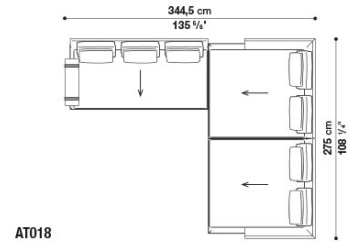

18

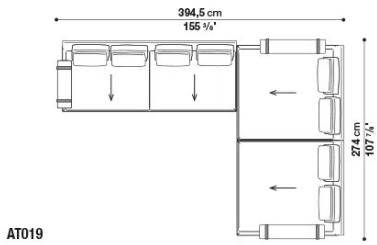

19

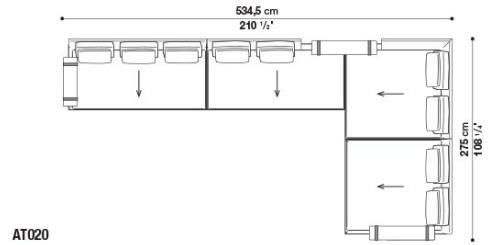

20

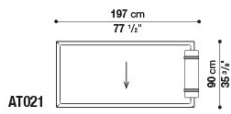

21

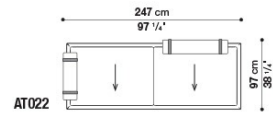

22

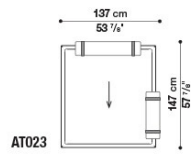

23

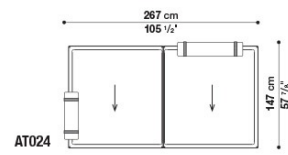

24

B&B Italia reserves the right to make technological and aesthetic improvements to its models, including changes to the sizes and materials, without notice. The technical drawings do not define the details of the product. The measurements shown are indicative and may undergo changes. In particular, the dimensions relevant to the padded parts are subject to usage tolerances over time caused by the normal adjustment of the padding. For the specific information, please contact the dealer closest to you.